

Product Feature

- Package Type: SIP-3 industrial standard
- Operating temperature range: -40°C - +85°C
- Support for negative output
- High efficiency up to 96%
- Output Short-Circuit Protection protection
- Fields of application: Power, industrial control, communications, internet of things, automotive, rail traffic, etc

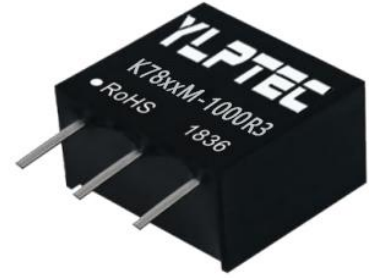

Selection Guide

Part No.	Input Voltage (VDC)	Output			Full Load Efficiency% (Min./Typ.)	Capacitive Load(μF) Max.
	Nominal (Range)	Voltage (VDC)	Current Min.(mA)	Current Max.(mA)		
K7803M-1000R3	24 (6-36)	3.3	0	1000	90/80	680
K7805M-1000R3	24 (8-36)	5	0	1000	93/85	680
	12 (8-27)	-5	0	-500	85/81	330
K7809M-1000R3	24 (13-36)	9	0	1000	94/89	680
K7812M-1000R3	24 (16-36)	12	0	1000	95/92	680
	12 (8-20)	-12	0	-300	88/87	330
K7815M-1000R3	24 (20-36)	15	0	1000	96/93	680
	12 (8-18)	-15	0	-300	87/88	330

Input Specifications

Item	Operating Conditions	Min.	Typ.	Max.	单位
No-Load Input Current	Positive Output	—	0.3	1	mA
Reverse the input		Avoid / Not protected			
Input Filter		Capacitance Filter			

Output Specifications

Item	Operating Conditions		Min.	Typ.	Max.	Unit
Output Voltage Accuracy	Full Load, Input Voltage Range	H7803-1000	--	±2	±4	
		Other Models	--	±1.5	±3	
Linear Regulation Rate	Full Load, Input Voltage Range		--	±0.2	±0.4	%
Load Regulation Rate	Nominal Input Voltage, 10% to 100% Load	Positive output	--	±0.4	±0.6	
		Negative output	--	±0.4	±0.8	
Ripple & Noise	20MHz Bandwidth, Nominal Input Voltage, 10% to 100% Load		--	20	75	mVp-p
Instantaneous Recovery	Nominal Input Voltage, 25% Load Step Change		--	0.2	1	ms
Transient Response			--	±60	±200	mv
Temperature Drift Coefficient	Operating Temperature -40 TO +85°C		--	--	±0.03	%/°C
Short-Circuit Protection	Nominal Input Voltage		Continuous, Self-Recovery			

General Specifications

Item	Operating Conditions	Min.	Typ.	Max.	Unit
Operating Temperature	Temperature ≥ 85 °C derating. (See Figure 1)	-40	--	85	°C
Storage Temperature		-55	--	125	°C
Storage Humidity	Non-condensing	--	--	95	%RH
Pin welding can withstand the highest temperature	Soldering spot is 1.5mm away from case for 10 seconds	--	--	300	°C
Switching Frequency		550	--	850	kHz
MTBF	MIL-HDBK-217F@25°C, Ground Benign	>2000Kh			

Mechanical Specifications

Case Material	Black plastic; flame-retardant and heat-resistant (UL94V-0 rated)
Package Dimensions	11.60 x 7.55 x 10.16 mm
Weight	1.8g (Typ.)
Cooling Method	Free air convection

EMC Specifications

EMI	CE	CISPR32/EN55032 CLASS B (The recommended circuit is shown in Figure 5-②)	
	RE	CISPR32/EN55032 CLASS B (The recommended circuit is shown in Figure5-②)	
EMS	ESD	IEC/EN61000-4-2	Contact ±4KV Perf.Criteria B
	RS	IEC/EN61000-4-3	10V/m Perf.Criteria A
	EFT	IEC/EN61000-4-4	±1KV (The recommended circuit is shown in Figure5-①) Perf.Criteria B
	Surge	IEC/EN61000-4-5	line to line ±1KV (The recommended circuit is shown in Figure 5-①) Perf.Criteria B
	CS	IEC/EN61000-4-6	3Vr.m.s Perf.Criteria A

Typical Characteristic Curves

Positive Output Efficiency VS Input Voltage (Full Load)

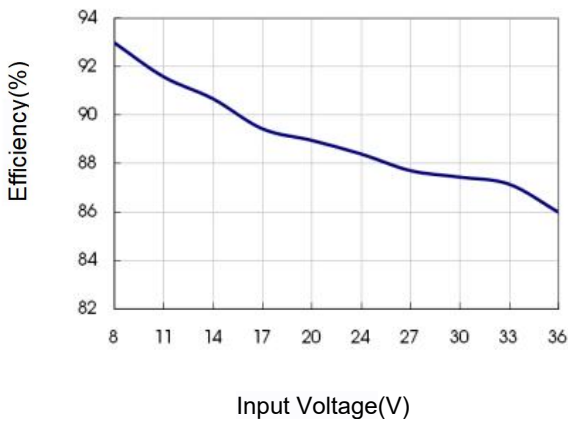

Positive Output Efficiency VS Output Load (Nominal Input)

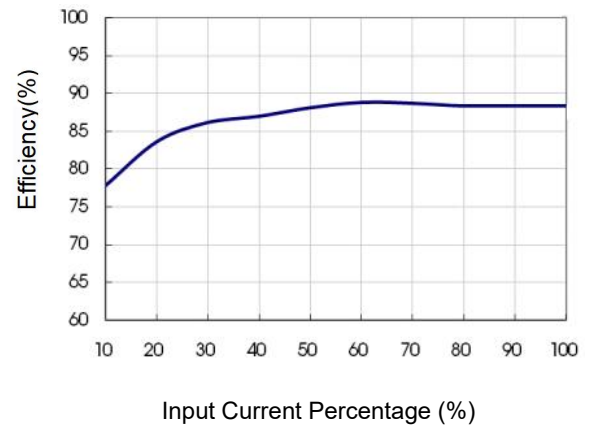

Temperature Derating Curve

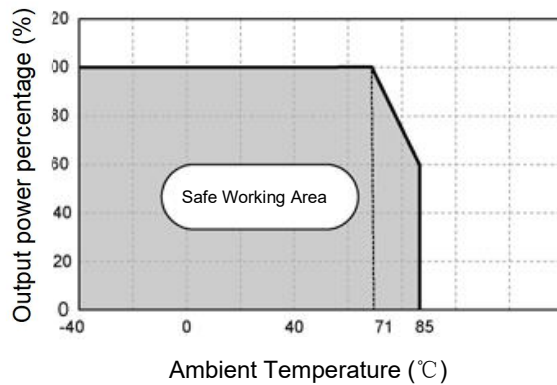

Figure 1

Typical Circuit Design And Application

Typical Application Circuit

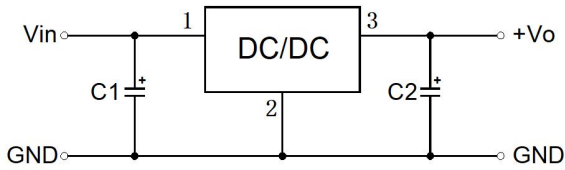

Figure 2-1 Positive output application circuit



Figure 2-2 Negative output application circuit

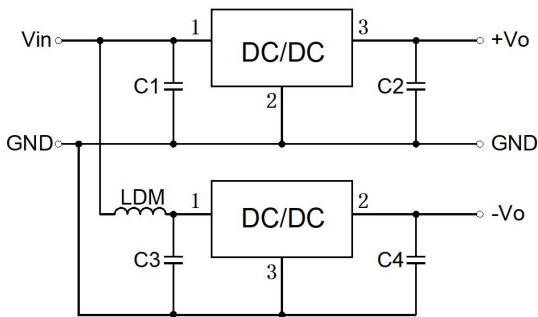

Figure 3

Parallel application circuit with positive and negative outputs

Capacity Value Reference Table

Product Model	C1/C3 (Ceramic Capacitor)	C2/C4 (Ceramic Capacitor)
H7803-1000	10uF/50V	22uF/10V
H7805-1000		22uF/10V
H7809-1000		22uF/16V
H7812-1000		22uF/25V
H7815-1000		22uF/25V

"LC" Filter Application Circuit

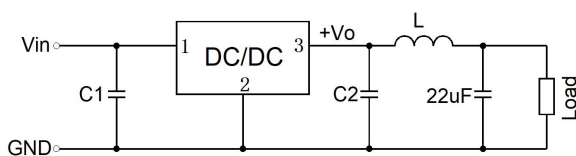

Figure 4-1 Positive output

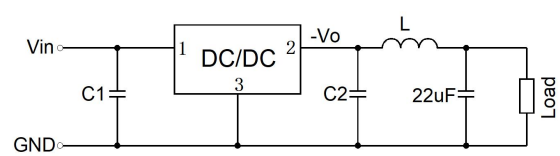

Figure 4-2 Negative output

Note:

- In general, we can be combined with the use of the product environment external capacitor C1 and C2(C3 and C4), and the capacitor position should be close to the pin end of the product;
- Capacity Value Reference Table is C1 and C2 (C3 and C4).The capacity can be appropriately increased according to the need, or the tantalum capacitor with low ESR and electrolytic capacitor can be used;
- When the product is used in the application circuit shown in Figure 3, it is recommended to add inductor LDM to reduce the interference between products. The recommended value of LDM is 10μH.
- This product does not support hot swap and the output terminals cannot be used in parallel;
- If the output ripple needs to be further reduced, we can attach an "LC" filter network to the output, the recommended value of L is 10μH-47μH, this is shown in Figure 4.

EMC Recommended Current

EMC Recommended Circuit

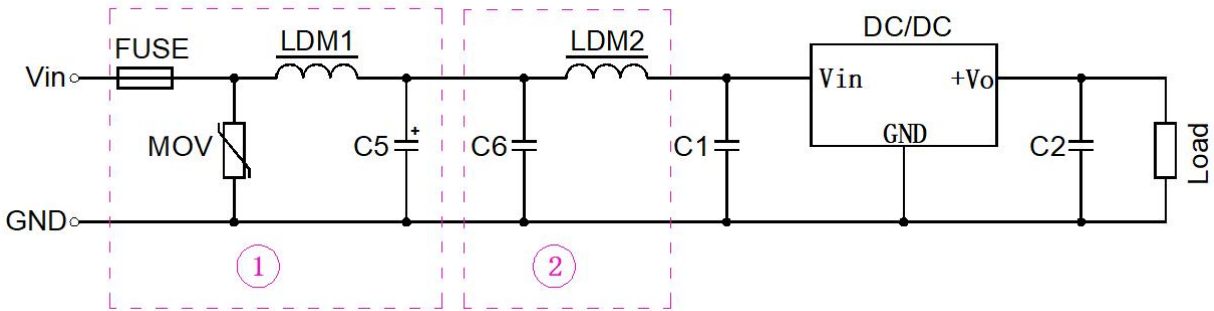

Figure 5

FUSE	MOV	LDM1	C5	C1/C2	C6	LDM2
According to the customer's actual input	20D470K	82μH	680μF/50V	Refer to Capacity Value Reference Table	4.7μF /50V	12μH

Note: Part ① in Figure 5 is for EMS test; Part ② in Figure 5 is used for EMI filtering, which can be selected according to the demand.

Dimensions and Recommended Layout

Dimensions

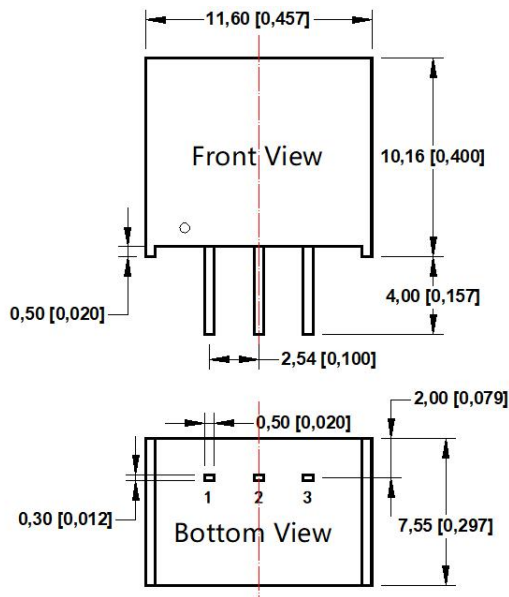

Pin Definition Table

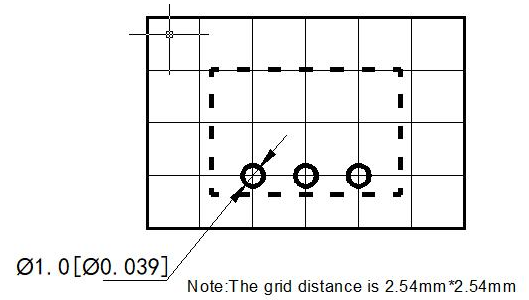

Pin	Positive Output	Negative Output
1	V _{in}	V _{in}
2	GND	-V _o
3	+V _o	GND

Note:

Unit: mm[inch]

Pin section tolerances: ±0.10[±0.004]

General tolerances: ±0.50[±0.020]

Note:

1. Maximum capacitive loads are tested in the input voltage range and under full load conditions;
2. Unless otherwise specified, the parameters in this datasheet were measured at 25°C, humidity 40%~75%, input nominal voltage and output pure resistance mode under full load;
3. Our company can provide product customization, specific needs can directly contact our technical personnel;
4. All index test methods are based on our company's enterprise standards;
5. The copyright and the right of final interpretation of the product belong to WIER Guangdong Science & Technology Co., Ltd.